

PRESSURE REDUCING VALVE

CHARACTERISTICS

The direct-acting pressure reducing valve is dedicated to applications on steam, compressed air and other gases. This device permits to lower the distribution system pressure to obtain the desired pressure for service. It has a compact ductile iron construction, with a built-in strainer and a high durability bellow. The downstream pressure can be easily adjusted thank to the thumbwheel. Non-tight device when mounted in-line. We recommend installing an upstream isolating valve.

LIMITS OF USE

Max. allowable upstream pressure	19 bar
Max. allowable downstream pressure	8.6 bar
Max. body pressure	PN 25
Max. allowable temperature	-10 °C / +210 °C
Hydraulic test pressure	38 bar
Max. flow ratio	10:1

Kv VALUES

DN	1/2"	3/4"	1"
Kv (m3/h)	1.5	2.5	3

DOWNSTREAM PRESSURE RANGE

Spring	Grey	Green	Orange
Downstream pressure (bar)	0.14 - 1.7	1.4 - 4	3.5 - 8.6

INSTALLATION

This pressure reducing valve has to be installed in a horizontal position. The flow should follow the direction of the arrow marked on the valve body.

The installation of an upstream Y-strainer is recommended

DIMENSIONS (mm)

DN	1/2"	3/4"	1"
A	85	98	110
B	126	126	126
C	65	65	65

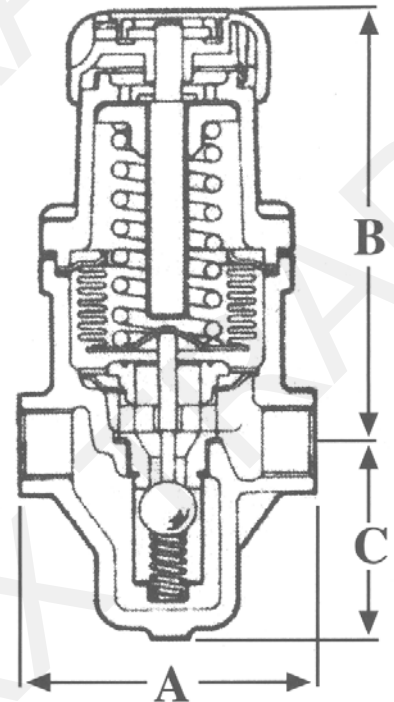

PRESSURE REDUCING VALVE

CONSTRUCTION

#	Item	Material
1	Spring rod	Aluminium
2	Adjustment thumbwheel	Polypropylene
3	Nut	Cast iron
4	Spring	Chrome plated steel + silicon
5	Bellow	AISI 316 stainless steel
6	Sealing gasket	Stainless steel
7	Nut	Steel Gr8.8
8	Body	GGG40.3 Ductile iron
9	Guiding ring	PTFE reinforced Graphite
10	Stem	Stainless steel
11	Seat	Stainless steel
12	Seat gasket	Stainless steel
13	Valve	AISI 316 stainless steel
14	Spring	AISI 316 stainless steel
15	Strainer	AISI 316 stainless steel
16	Indicator	Polypropylene
17	Divider	AISI 316 stainless steel
18	Pin	Steel

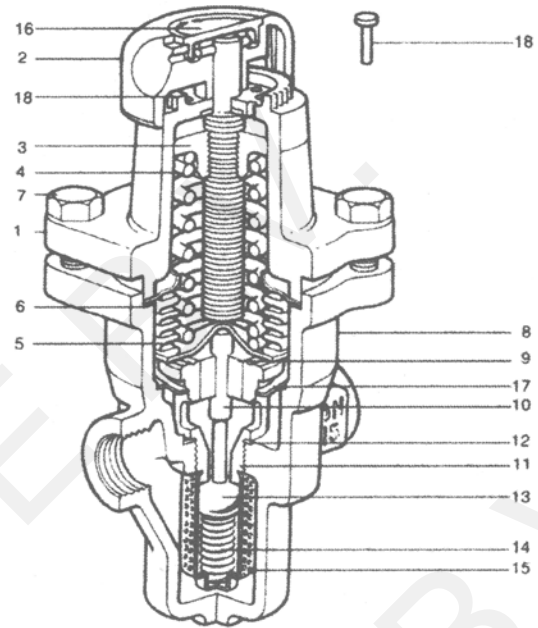

FLOW RATE CHART

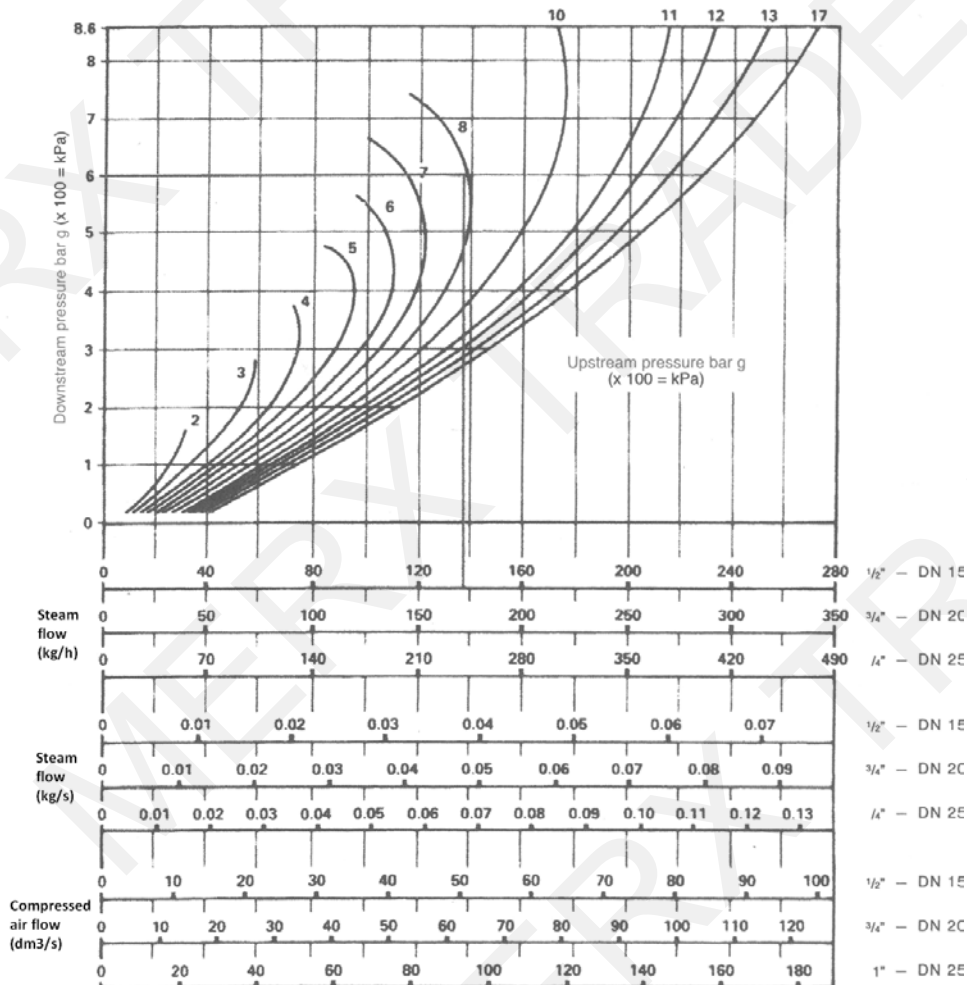

Technical data given for information purpose only. May be subject to alteration without prior notice

Information provided as an indication and subject to possible modification. Colours and details can be different then shown in data sheets or pictures. Merxtrade BV has no liability for any damages by use off any information, displayed on these pages.